

# GL7000 Voltage Module USER'S MANUAL

Thank you very much for buying this GRAPHTEC product.

This item is a standalone measuring module. Please use it by installing it on the main module.

These directions describe preparations and cautions before measurement.

**For safe use, please make sure to read "4 Regarding Maximum Input Voltage"**

**For the details concerning operation procedures etc., read the User's manual recorded on the CD-ROM (included with the main module)**

### Confirmation of the exterior

After opening the package, please confirm that there are no problems (scratches and dirt) on the exterior before use.

### Confirmation of the attached items.

- User's manual (this book): 1

If by any chance faults are found, please contact the store where you bought the item.

\* Please note that items mentioned in this book may change without prior notice.

## 1 Part Names

Explanation of the module's part names and functions.

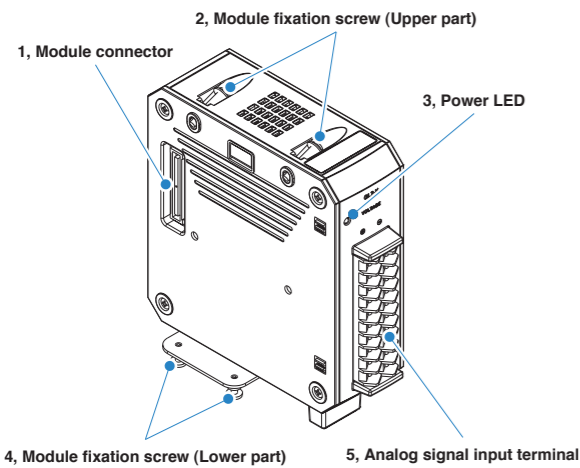

- 1, **Module connector**..... Connector for connecting all kinds of modules.
- 2, **Module fixation screw**..... Fixation screw for the adjoining module. To prevent drop off, do not remove from the module.
- 3, **Power LED**..... The Power LED will light up green when the power has been turned on and the module has been recognized.
- 4, **Module fixation screw**..... Fixation screw for the adjoining module. (Lower part)
- 5, **Analog signal input terminal**.. Terminal for inputting analog measurements.

## 2 How to Install Module

This explains how to attach the module to the main module.

**CAUTION** When installing or removing the module, please make sure that the power is off.

- 1, Remove the fixation screws (4 places on the upper part and lower parts), place the alarm module parallel to the main module and slide it in the direction of the arrow.

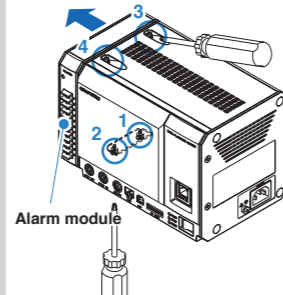

- (1) Remove the fixation screws from the 2 places on the lower part.
- (2) Loosen the drop-off prevention screws on the upper part in 2 places.
- (3) Removing the alarm module.

**CAUTION**

Slide it in the direction of the arrow. If you pry it at an angle there is a risk of damaging the connector.

- 2, Remove the voltage module's fixation screws (2 places on the lower part)

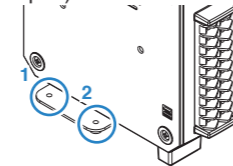

- 3, Slide the voltage module parallel to the main module and connect the connector.

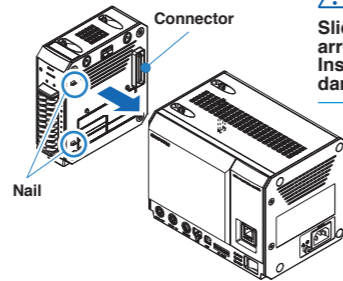

**CAUTION**

Slide it in the direction of the arrow. Inserting it at an angle may cause damage to the nails.

- 4, Fix the voltage module and the main module in place with the screws.(4 places on the upper and lower parts)

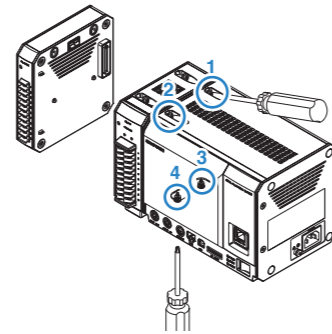

- 5, Similarly, install the alarm module on the last part and fix it with screws.

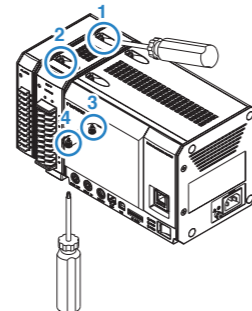

During installation, a 4kgf.cm screw tightening torque is recommended.

## 3 How to Connect to Analog Signal Terminal

This explains how to connect the input cable.

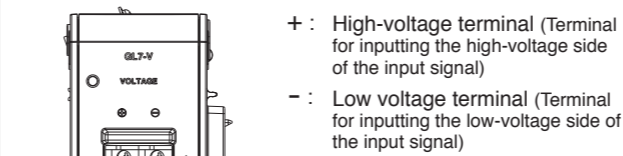

**WARNING**

During wiring, confirm that the signal's supply source is turned OFF to prevent electrical shocks.

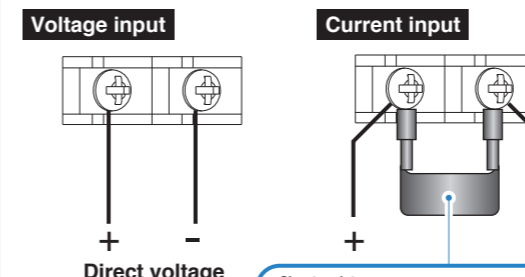
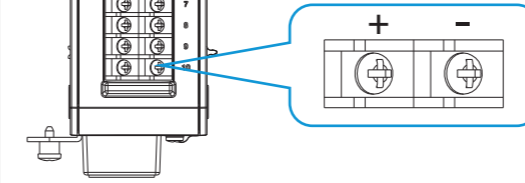

**Shunt resistance**  
 Example: In the case of 4-20 mA, apply 250Ω (±0.1%) and measure in the 1-5 V range.  
 \* For shunt resistance, we recommend the use of the optional B-551.

## 4 Regarding Maximum Input Voltage

To avoid break-downs or short-circuiting accidents, please make sure to abide by the items written below.

### Maximum input voltage

- In case the input voltage exceeds the specifications, the circuit at the input part will break down so even if the input voltage exceeds the specifications only for an instant, please don't input.
- Please take care that no static electricity is applied on the analog signal input terminal.

**<Input terminal +/- terminal interval (A etc. on the figure below)>**

Maximum input voltage : 100 mV to 1 V range 60Vp-p  
 : 2 V to 100 V range 100Vp-p

**<Input terminal (-)/Input terminal (-) interval (B etc. on the figure below)>**

Maximum input voltage: 60Vp-p  
 Withstand voltage: 1000Vp-p/1 minute

**<Input terminal (-)/GND terminal interval C etc. on the figure below>**

Maximum input voltage: 60Vp-p  
 Withstand voltage: 1000Vp-p/1 minute

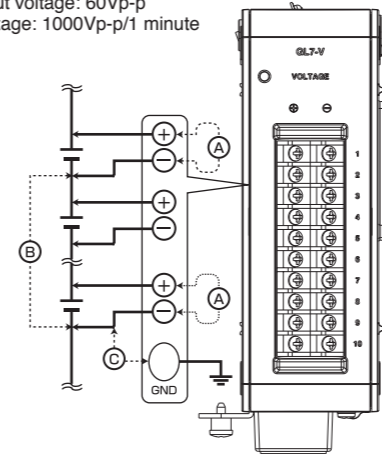

## 5 Noise Countermeasures

In case the measured values fluctuate due to exogenous noise, the following measures are recommended. (Depending on the type of noise, the result may change.)

- **Make absolutely sure to ground the chassis GND of the measuring object**  
 Absolutely making sure to ground the chassis GND of the measuring object to a favorable ground may have an effect.
- **Connecting the chassis GNDs of the measuring object and the instrument**  
 Connecting the chassis GND of the measuring object and the GND terminal of the main module with an electrical cable as short and thick as possible, and further gaining potential equalization by grounding it may have an effect.

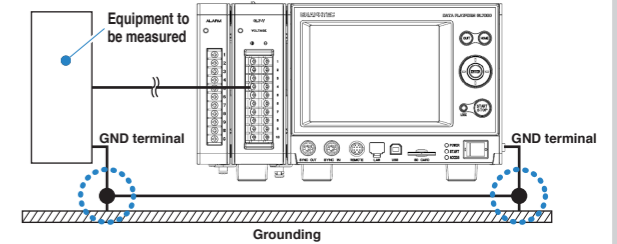

- **Using the filter function of the instrument**  
 Setting the filter to anything but OFF on the main body's input settings menu.

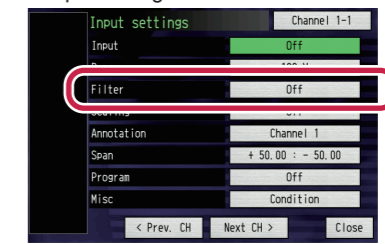

(Screen for when the optional display module is connected)

For details, please refer to the User's manual recorded on the CD-ROM (included with the main module)

## 6 Specifications

GL7-V (Voltage Module) specifications

Item	Contents
Input ch number	10 ch/1 module
Input terminal shape	M3 screw type terminal
System	All ch insulation, simultaneous sampling, unbalanced input
Sampling interval	1, 2, 5, 10, 20, 50, 100, 125, 200, 250, 500 msec, 1, 2, 5, 10, 20, 30 sec, 1, 2, 5, 10, 20, 30 min, 1 hour
Built-in RAM	2,000,000 data
Measurement range	100, 200, 500 mV, 1, 2, 5, 10, 20, 50, 100 V, 1-5 V F.S.
Measurement accuracy (23°C±5°C)	±0.25% of F.S. * At least 30 minutes after turning on the power, sampling 1 sec, Filter Line, GND connection
A/D converter	System: sequential comparison system Resolution: 16-bit (Effective ability: Approximate ± range 1/40,000)
Temperature coefficient	Gain: ±0.01% of F.S./°C Zero: ±0.02% of F.S./°C
Input resistance	1MΩ ±5%
Input signal source resistance	1kΩ or less
Maximum input voltage	Input terminal +/- interval : 100 mV to 1 V range 60vp-p : 2 V to 100 V range 100Vp-p Input terminal (-)/(-) interval: 60Vp-p Input terminal (-)/GND interval: 60Vp-p
Withstand voltage	Input terminal (-)/(-) interval: 1000Vp-p/1 minute Input terminal (-)/GND interval: 1000Vp-p/1 minute
Insulation resistance	Input terminal (-)/GND interval: 50MΩ or more (at DC500 V)
Common mode rejection	90 dB or more (50/60 Hz signal source 300Ω or less)
S/N (Noise)	48 db or more (+/- at short)
Frequency response	DC to 1 kHz (+1/-3 dB)
Filter	LPF : OFF, Line (1.5 Hz), 5 Hz, 50 Hz, 500 Hz (Attenuation) -3dB (-5.2dB to -1.4dB) /6dB oct
External dimensions [WxDxH] (approximate)	49.2 x 136 x 160 mm (not including protruding parts)
Weight	840g